

# Sturt

CRISP LINES



ST301 DISPLAYED

## ST139 1/2 BOWL

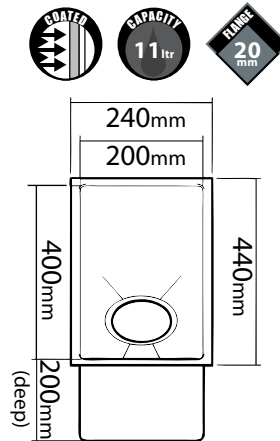

### Features TM FM UM

- 90mm designer waste (1 inc)
- Rear waste position
- Coated & Padded
- 18/10 Stainless Steel @ 1.2mm
- 20mm polished flange

#### SPECIAL FEATURE

10mm radius corners  
Ideal for weld-in applications

## ST146 MAIN BOWL

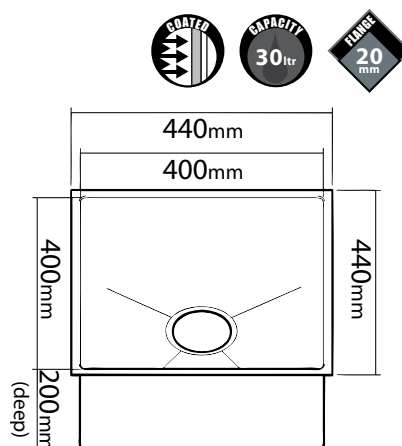

### Features TM FM UM

- 90mm designer waste (1 inc)
- Rear waste position
- Coated & Padded
- 18/10 Stainless Steel @ 1.2mm
- 20mm polished flange

#### SPECIAL FEATURE

10mm radius corners  
Ideal for weld-in applications

### ST148 MAXI BOWL

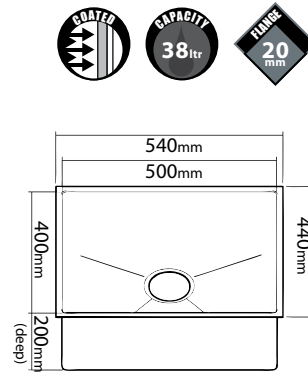

#### Features



- 90mm designer waste (1 inc)
- Rear waste position
- Coated & Padded
- 18/10 Stainless Steel @ 1.2mm
- 20mm polished flange

#### SPECIAL FEATURE

10mm radius corners  
Ideal for weld-in applications

### ST302 1 & 1/2 BOWLS

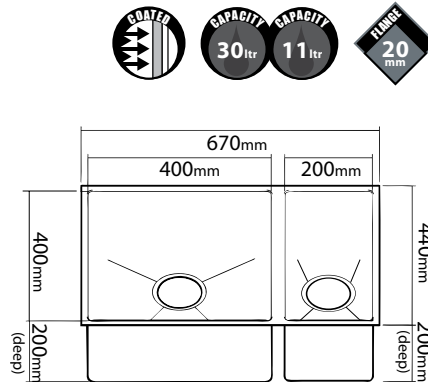

#### Features



- 90mm designer waste (2 inc)
- Rear waste position
- Coated & Padded
- 18/10 Stainless Steel @ 1.2mm
- 20mm polished flange
- Bridge width 30mm
- RH option only, not reversible

#### SPECIAL FEATURE

10mm radius corners  
Ideal for weld-in applications

### ST301 MEDIUM & MAIN BOWLS

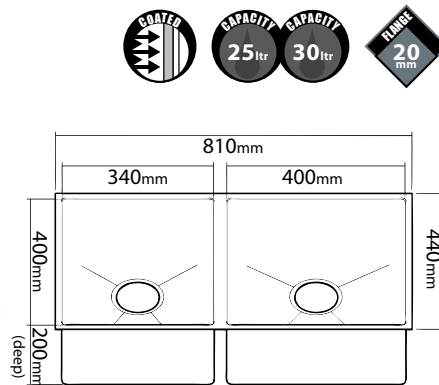

#### Features



- 90mm designer waste (1 inc)
- Rear waste position
- Coated & Padded
- 18/10 Stainless Steel @ 1.2mm
- 20mm polished flange
- Bridge width 30mm
- LH option only, not reversible

#### SPECIAL FEATURE

10mm radius corners  
Ideal for weld-in applications

### Accessories

#### AC056



Prep Colander tray  
Stainless Steel  
400mm x 250mm

#### AC301



Colander  
Stainless Steel  
400mm x 200mm x 80mm

#### AT140

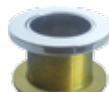

Mixer Mate:  
Protective Benchtop  
Substrate Guard

#### AD024

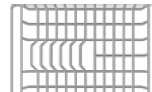

Dishrack  
Stainless Steel  
300 x 400 mm

#### AF141



Oak food board  
400mm x 200mm

#### AT130



Drainer tray  
Stainless Steel  
400mm x 400mm